



JIB FURLING & REEFING SYSTEM



Spare Part List

Type C & D

Worldwide dealer list

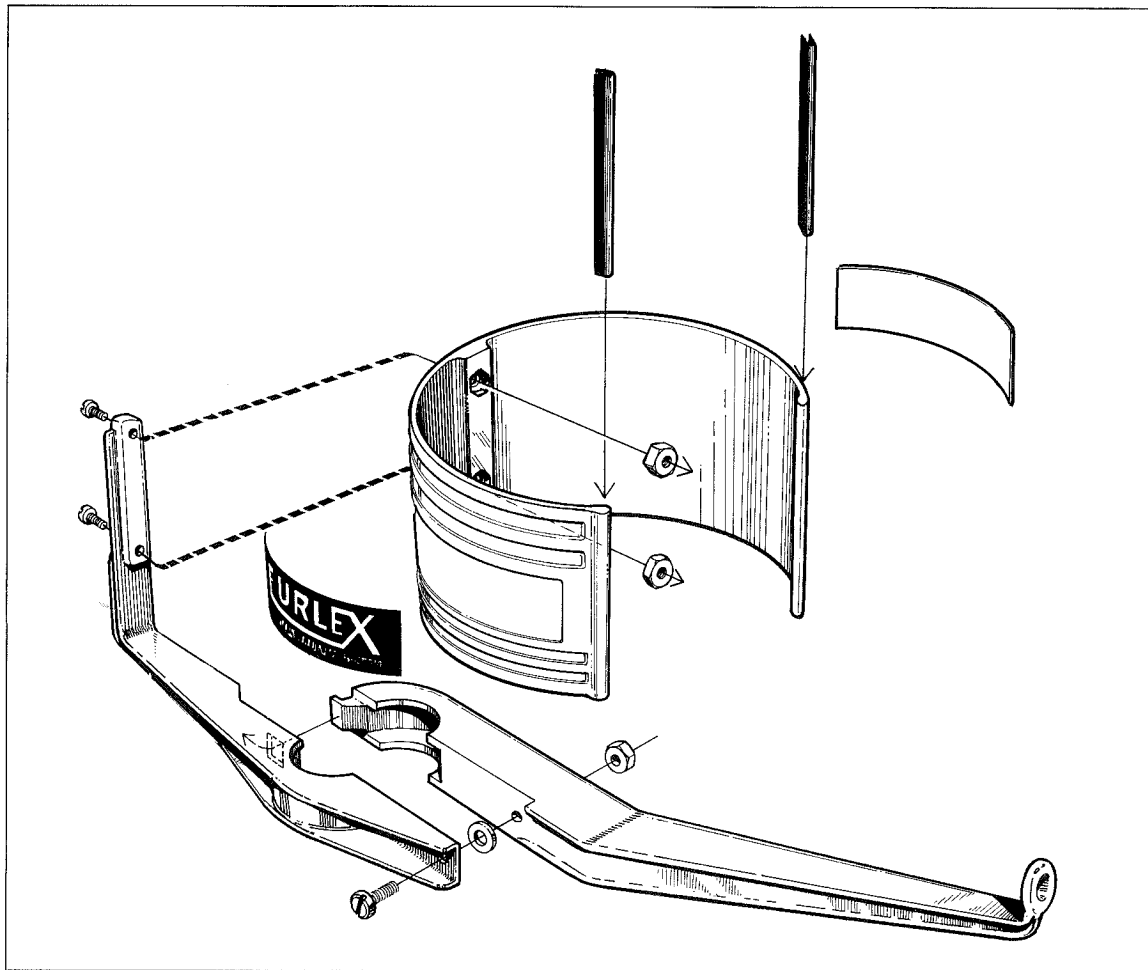

SELDÉN

DESCRIPTION A

HALYARD SWIVEL

Item	Description	Type C				Type D			
		Dimension	Qty	Forestay wire size		Dimension	Qty	Forestay wire size	
				ø8 mm	ø10 mm			ø12 mm	ø14 mm
		Assembly number →		539-201-01	539-201-01	Assembly number →		539-101-01	539-101-01
A 1	Sliding sleeve	ø60 × 190	1	539-207	539-207	ø74 × 230	1	539-122	539-122
A 2	Locking nut	M6	2	158-005	158-005	M8	2	158-006	158-006
A 3	Hub — Halyard swivel	ø102 × 140	1	539-201	539-201	ø128 × 164	1	539-101	539-101
A 4	Ball bearing ring — inner	ø84 × ø66 × 8	1	539-220	539-220	ø104 × ø86 × 8	1	539-110	539-110
A 5	Balls	ø8	30	539-128	539-128	ø8	38	539-128	539-128
A 6	Ball bearing ring — outer	ø90 × ø66 × 11	1	539-219	539-219	ø110 × ø86 × 12	1	539-109	539-109
A 7	Intermediate ring	ø88 × ø67 × 9	1	539-218	539-218	ø110 × ø86 × 13	1	539-112	539-112
A 8	Eye ring-rotating-1 boss	ø102 × 60	1	539-203	539-203	ø128 × 70	1	539-103	539-103
A 9	Intermediate ring	ø88 × ø67 × 9	1	539-218	539-218	ø110 × ø86 × 13	1	539-112	539-112
A10	Ballbearing ring — outer	ø90 × ø66 × 11	1	539-219	539-219	ø110 × ø86 × 12	1	539-109	539-109
A11	Balls	ø8	30	539-128	539-128	ø8	38	539-128	539-128
A12	Ball bearing ring — inner	ø84 × ø66 × 8	1	539-220	539-220	ø104 × ø86 × 8	1	539-110	539-110
A13	Screw	MFX6 × 25	2	162-032	162-032	MFX8 × 30	2	162-034	162-034
A14	Flange eye collar	ø102 × 45	1	539-202	539-202	ø128 × 50	1	539-102	539-102
A15	Snap shackle	85 mm	1	307-336	307-336	120 mm	1	307-340	307-340

Forestay wiresize is marked at the ball bearing socket (Item B5)

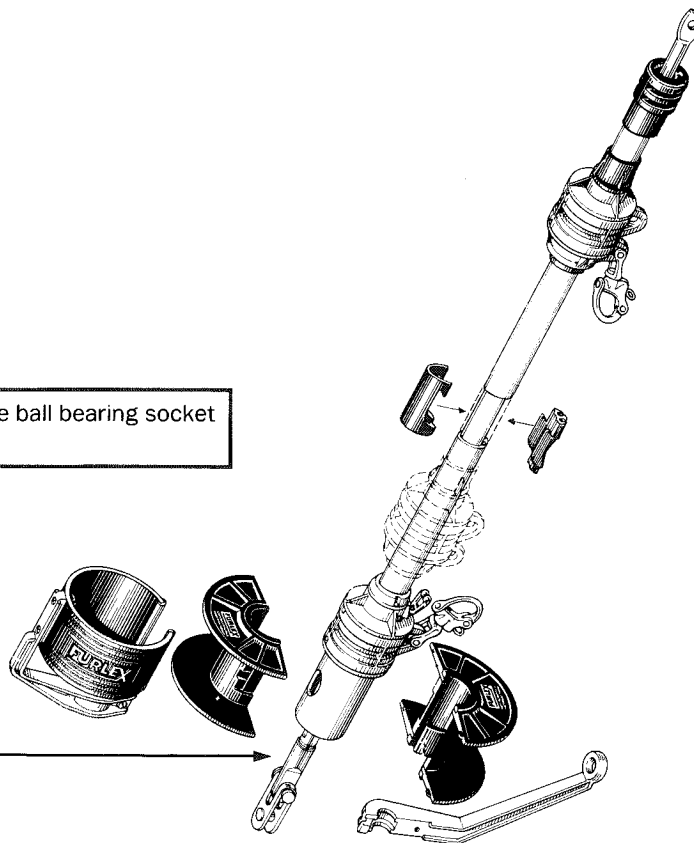

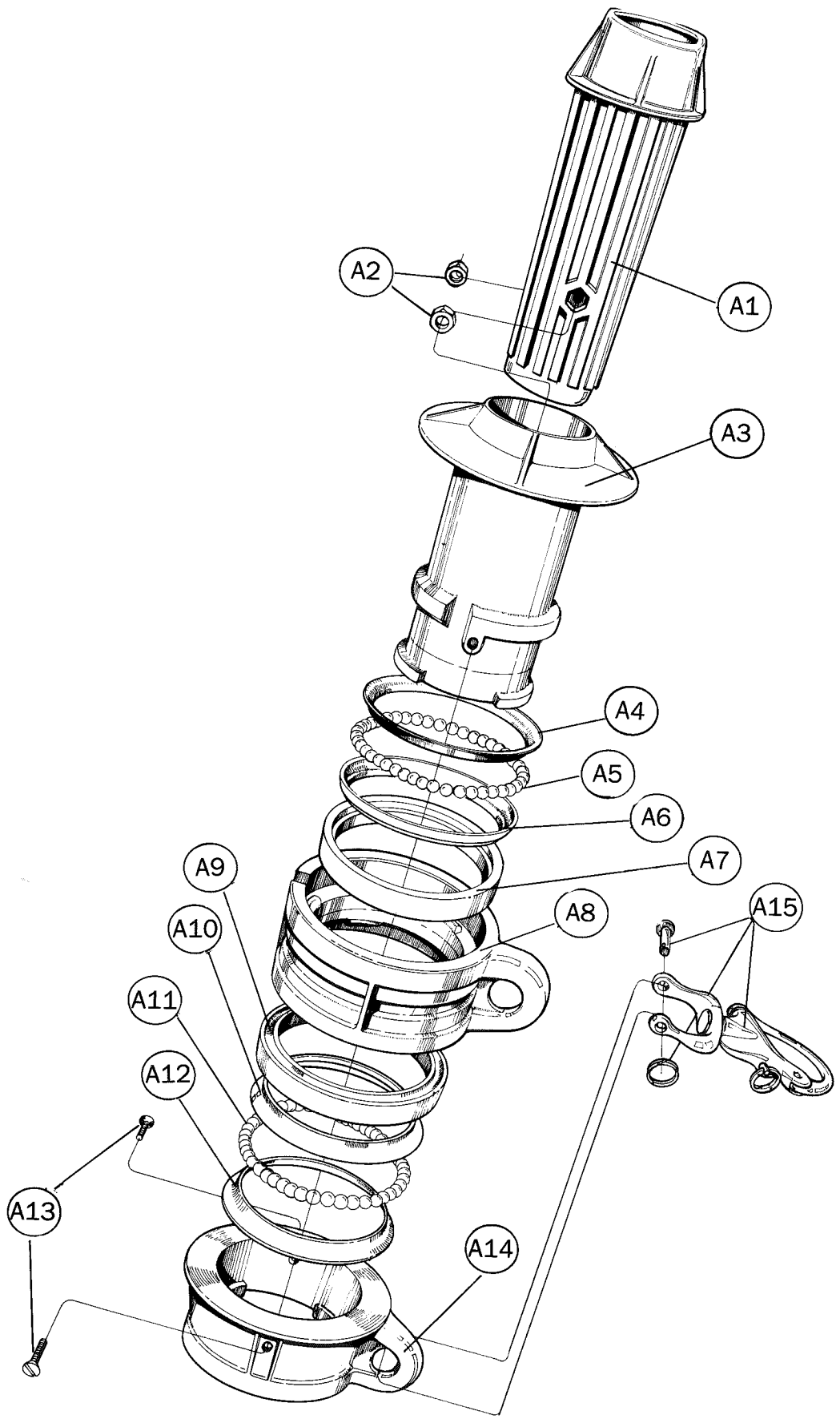

DESCRIPTION B

LOWER SWIVEL

Item	Description	Type C				Type D			
		Dimension	Qty	Forestay wire size		Dimension	Qty	Forestay wire size	
				ø8mm	ø10 mm			ø12 mm	ø14 mm
		Assembly number →	539-204-01	539-204-02	Assembly number →	539-104-01	539-104-02		
B 1	Adapter	ø58 × 75	1	539-206 1)	539-206 1)	ø70 × 75	1	539-107 1)	539-107 1)
B 2	Screw	MFX 6 × 40	2	162-024	162-024	MFX 6 × 40	2	162-024	162-024
B 3	Spring pin	ø5 × 20	1	166-513	166-513	ø5 × 20	1	166-513	166-513
B 4	Sheave	ø23 × ø6 × 10	1	504-310	504-310	ø23 × ø6 × 10	1	504-310	504-310
B 5	Ball bearing socket	Wiredim. mark.	1	301-172 2)	301-173 2)	Wiredim. mark.	1	301-160 2)	301-161 2)
B 6	Balls	ø8	12	539-128	539-128	ø8	15	539-128	539-128
B 7	Ball bearing ring — outer	ø44 × ø26 × 8	1	539-223	539-223	ø52 × ø34 × 8	1	539-111	539-111
B 8	Lubricate screw	M8 × 10	1	319-571	319-571	M8 × 10	1	319-571	319-571
B 9	Locking nut	M6	2	158-005	158-005	M6	2	158-005	158-005
B10	Locking nut	M6	2	158-005	158-005	M6	2	158-005	158-005
B11	Inner hub — lower swivel	ø102 × 236	1	539-204	539-204	ø128 × 269	1	539-104	539-104
B12	Ball bearing ring — inner	ø84 × ø66 × 8	1	539-220	539-220	ø104 × ø86 × 8	1	539-110	539-110
B13	Balls	ø8	30	539-128	539-128	ø8	38	539-128	539-128
B14	Ball bearing ring outer	ø90 × ø66 × 11	1	539-219	539-219	ø110 × ø86 × 12	1	539-109	539-109
B15	Intermediate ring	ø88 × ø67 × 9	1	539-218	539-218	ø110 × ø86 × 13	1	539-112	538-112
B16	Snap shackle	85 mm	1	307-336	307-336	120 mm	1	307-340	307-340
B17	Eye ring-rotating boss	ø102 × 60	1	539-203	539-203	ø128 × 70	1	539-103	539-103
B18	Intermediate ring	ø88 × ø67 × 9	1	539-218	539-218	ø110 × ø86 × 13	1	539-112	539-112
B19	Ball bearing ring — outer	ø90 × ø66 × 11	1	539-219	539-219	ø110 × ø86 × 12	1	539-109	539-109
B20	Balls	ø8	30	539-128	539-128	ø8	38	539-128	539-128
B21	Ball bearing ring — inner	ø84 × ø66 × 8	1	539-220	539-220	ø104 × ø86 × 8	1	539-110	539-110
B22	Outer hub — lower swivel	ø102 × 135	1	539-205	539-205	ø128 × 155	1	539-105	539-105
B23	Screw	MFX 6 × 12	2	162-030	162-030	MFX 6 × 12	2	162-030	162-030
B24	Insert thread	—	—	—	—	M8 × 5	4	170-102	170-102
B25	Ball bearing ring — outer	ø44 × ø26 × 8	1	539-223	539-223	ø52 × ø34 × 8	1	539-111	539-111
B26	Balls	ø8	12	539-128	539-128	ø8	15	539-128	539-128
B27	Grub screw	MSK6SS 6 × 6	1	153-101	153-101	MSK6SS 6 × 6	1	153-101	153-101
B29	Wedge	L = 42	1	301-154	—	L = 65	1	301-156	—
B29	Wedge	L = 50	1	—	301-155	L = 77	1	—	301-162
B30	Former	ø16,3	1	301-159	—	ø24,8	1	301-164	—
B30	Former	ø19,2	1	—	301-163	ø31,0	1	—	301-165
B31	Terminal eye fitting	ø25 × 78	1	301-168 2)*)	—	ø35 × 110	1	301-170 2)*)	—
B31	Terminal eye fitting	ø28 × 90	1	—	301-169 2)*)	ø41 × 134	1	—	301-171 2)*)

*) Alt. use a standard STALOK eye

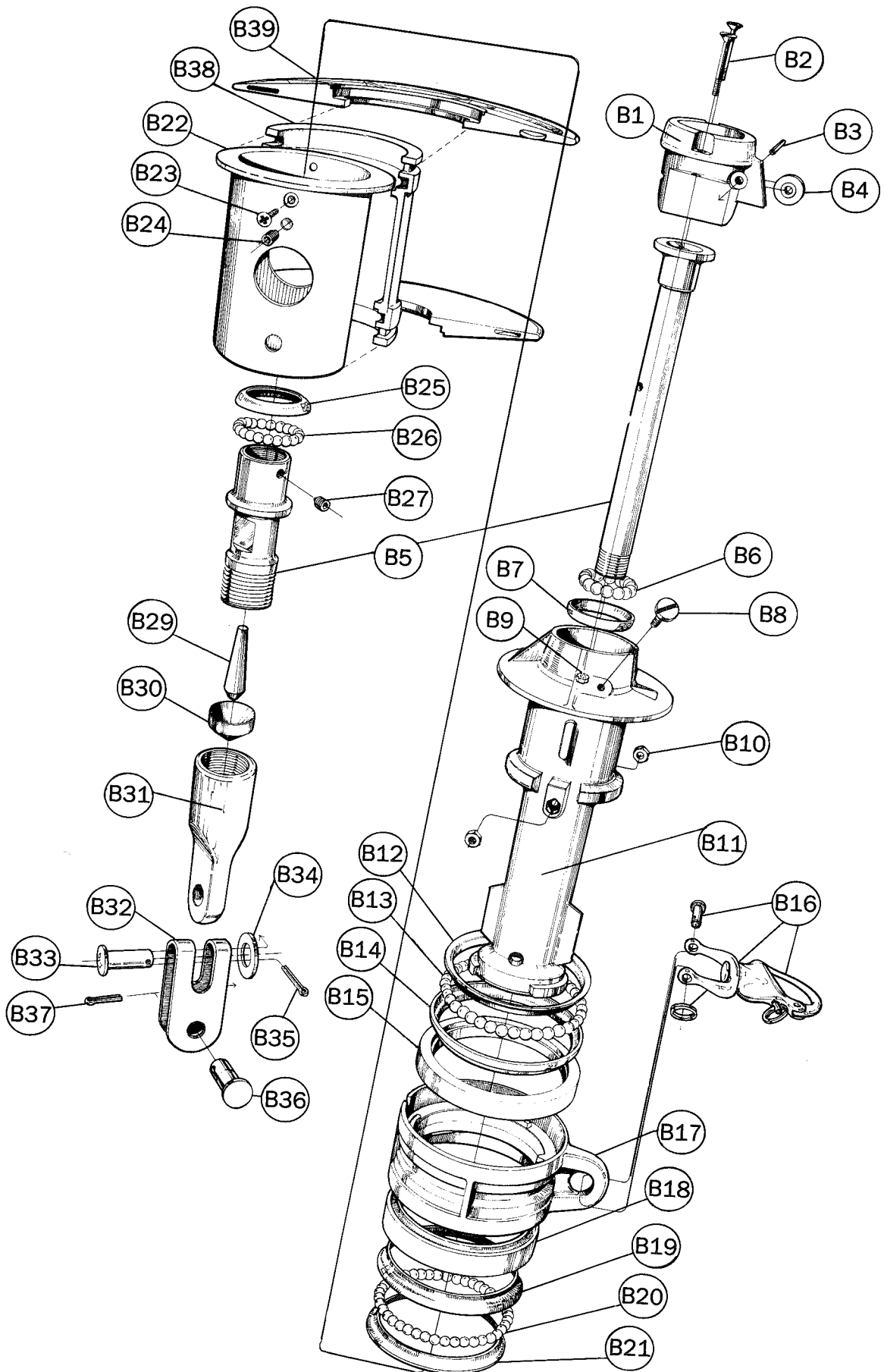

Continued from page 4

Item	Description	Type C				Type D			
		Dimension	Qty	Forestay wire size		Dimension	Qty	Forestay wire size	
				ø8mm	ø10 mm			ø12 mm	ø14 mm
B32	Toggle — fork/fork	Part no marked	1	517-048 3) 4)	517-051 3) 4)	Part no marked	1	517-052 3) 4)	517-053 3) 4)
B33	Clevis pin	ø14 × 47	1	165-503 4)	—	ø19 × 58	1	165-582 4)	—
B33	Clevis pin	ø14 × 47	1	—	165-503 4)	ø22 × 60	1	—	165-595 4)
B34	Washer	ø24 × ø14.2 × 2	2	164-420 4)	164-420 4)	ø36 × ø20 × 3	1	164-421 4)	—
B34	Washer	—	—	—	—	ø40 × ø23 × 3	1	—	164-422 4)
B35	Split pin	ø4 × 20	1	301-053 4)	301-053 4)	ø5 × 28	1	301-054 4)	301-054 4)
B36	Clevis pin	ø14 × 31	1	165-501 3) 4)	—	ø19 × 40	1	165-581 3) 4)	—
B36	Clevis pin	ø14 × 35	1	—	165-504 3) 4)	ø22 × 47	1	—	165-594 3) 4)
B37	Split pin	ø4 × 20	1	301-053 3) 4)	301-053 3) 4)	ø5 × 28	1	301-054 3) 4)	301-054 3) 4)
1)	Only as a package B1-B4		1	539-206-01	539-206-01		1	539-107-01	539-107-01
2)	Only as a package B5, B27-B31		1	301-172-01	301-173-01		1	301-160-01	301-161-01
3)	B32, B36, B37 also as a pack		1	517-048-01	517-051-01		1	517-052-01	517-053-01
4)	B32-B37 also as a pack		1	517-048-02	517-051-02		1	517-052-02	517-053-02

		Assembly number →		539-221-01	539-221-01				
B38	Line drum hub — half	ø94 × 130	1	539-221 1)	539-221 1)	—	—	—	—
B39	Line drum flange — half	ø210 × 14	2	539-222 1)	539-222 1)	—	—	—	—
—	Label flange	80 × 40	1	591-272	591-272	—	—	—	—
—	Label flange	42 × 16	1	591-238	591-238	—	—	—	—
1)	Only as a package B38-B39		1	539-221-01	539-221-01	—	—	—	—

						Assembly number →		539-108-01	539-108-01
B40	Line drum half	—	—	—	—	ø250 × 148	1	539-108	539-108
B41	Screw	—	—	—	—	MF8 8 × 16	2	162-033	162-033
B42	Washer	—	—	—	—	ø15 × ø8 × 2	2	164-031	164-031

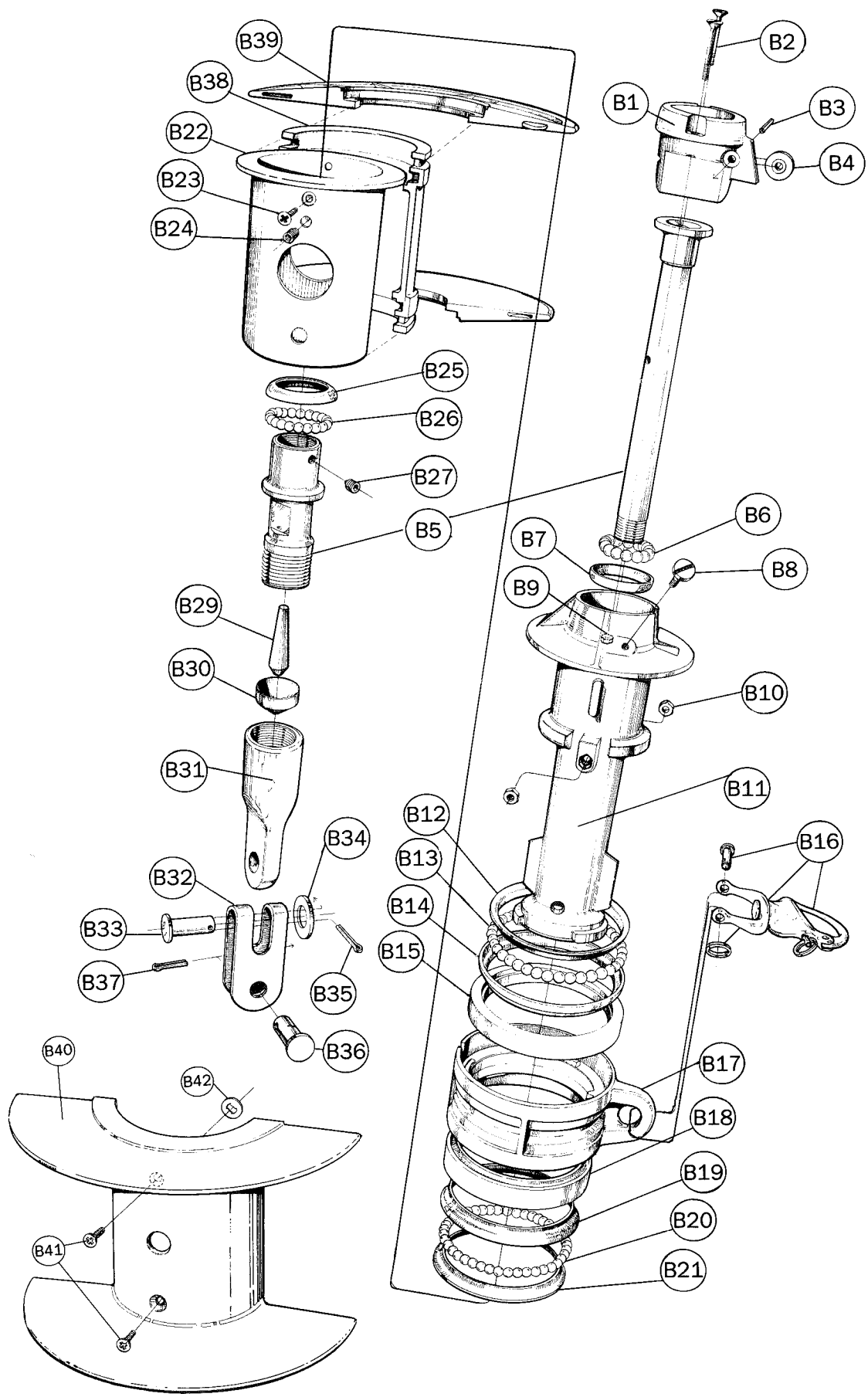

DESCRIPTION C

LINE GUARD FITTING

Item	Description	Type C				Type D			
		Dimension	Qty	Forestay wire size		Dimension	Qty	Forestay wire size	
				ø8mm	ø10 mm			ø12 mm	ø14 mm
		Assembly number →		539-215-01	539-216-01	Assembly number →		539-117-01	539-118-01
C 1	Screw	MRX 6 × 14	2	155-623	155-623	MRX 6 × 16	4	155-610	155-610
C 2	Line guard bracket	Part no marked	1	539-215	539-216	Part no marked	1	539-117	539-118
C 3	Anti-loss washer	ø16 × ø8 × 2	1	164-032	164-032	ø16 × ø8 × 2	1	164-032	164-032
C 4	Screw	M8 × 25	1	153-052	153-052	M8 × 25	1	153-052	153-052
C 5	Line guard saver	8 × 96	2	539-225 1)	539-225 1)	8 × 126	2	539-120 1)	539-120 1)
C 6	Line guard	ø160 × 97	1	539-224 1)	539-224 1)	ø178 × 127	1	539-119 1)	539-119 1)
C 7	Lockning nut	M 6	2	158-005	158-005	M 6	4	158-005	158-005
C10	Label line guard	34 × 117	2	591-240	591-240	39 × 132		591-241	591-241
		Assembly number →		539-213-01	539-214-01	Assembly number →		539-114-01	539-115-01
C 8	Locking nut	M 8	1	158-006	158-006	M 8	1	158-006	158-006
C 9	Line guide arm	Part no marked	1	539-213 2)	539-214 2)	Part no marked	1	539-114 2)	539-115 2)
1)	Only as a package C1, C5-C7, C10		1	539-224-01	539-224-01		1	539-119-01	539-119-01
2)	Only as a package C8-C9		1	539-213-01	539-214-01		1	539-114-01	539-115-01

DESCRIPTION E

Item	Description	Type C				Type D			
		Dimension	Qty	Forestay wire size		Dimension	Qty	Forestay wire size	
				ø8mm	ø10 mm			ø12 mm	ø14 mm
E 1	Forestay wire pack	L = 15500	1	601-006-25	—	L = 20400	1	601-009-11	601-010-10
E 1	Forestay wire pack	L = 17900	1	601-006-24	601-008-20	L = 22800	1	601-009-12	601-010-11
E 1	Forestay wire pack	L = 20300	1	—	601-008-21	—	—	—	—
E 2	Furling line	ø10, L = 28000	1	611-022-01	611-022-01	ø12, L = 40000	1	611-023-01	611-023-01
	Halyard lead set	Assembly number →		508-128-03	508-128-03	Assembly number →		508-128-03	508-128-03
E 3	Halyard lead	57-ø20	1	508-128 5)	508-128 5)	Large	1	508-128 5)	508-128 5)
E 4	Selftapping screw	MRX-TT 6 × 12	3	155-703 5)	155-703 5)	MRX-TT 6 × 12	3	155-703 5)	155-703 5)
E 5	Insulator	60 × 54	1	530-627 5)	530-627 5)	60 × 54	1	530-627 5)	530-627 5)
	Prefeeder package	Assembly number →		505-517-03	505-517-03	Assembly number →		505-517-02	505-517-02
E 6	Prefeeder	46 × 22	1	505-517 3)	505-517 3)	46 × 22	1	505-517 3)	505-517 3)
E 7	Rubber cord	ø6, L = 1200	1	61401003 3)	61401003 3)	ø8, L = 1200	1	61401102 3)	61401102 3)
E 8	Hook for rubber cord	ø1,2 × 50	1	539-047 3)	539-047 3)	ø1,5 × 53	1	539-130 3)	539-130 3)
E 9	Stanchion block	For ø25 mm	1	538-971-01	538-971-01	—	—	—	—
E 9	Stanchion block, 4-pack	For ø25 mm	1	538-971-02	538-971-02	—	—	—	—
	Stanchion block	—	—	—	—	For ø25 mm	1	538-961	538-961
E11	Locking adhesive	10 g	1	312-305	312-305	10 g	1	312-305	312-305
E12	Luff extrusion sample	Type C, L = 140	1	539-211	539-211	Type D, L = 140	1	539-126	539-126
E13	Manual (English text)	A4	1	595-019-E	595-019-E	A4	1	595-019-E	595-019-E
E13	Manual (Swedish text)	A4	1	595-019-S	595-019-S	A4	1	595-019-S	595-019-S
E13	Manual (German text)	A4	1	595-019-T	595-019-T	A4	1	595-019-T	595-019-T
E14	Spare parts list	A4	1	595-046-E	595-046-E	A4	1	595-046-E	595-046-E
E15	Lubricating grease	100 g	1	312-501	312-501	100 g	1	312-501	312-501
		Assembly number →		539-226-01	539-226-01	Assembly number →		539-132-01	539-132-01
E16	Top guard	ø52 × 70	1	539-226 4)	539-226 4)	ø65 × 80	1	539-132 4)	539-132 4)
E17	Screw	RXS Z 4,8 × 9,5	2	171-019	171-019	CSS B 4,8 × 13	4	171-007	171-007
3)	Only as a package E6-E8		1	505-515-03	505-515-03		1	505-515-01	505-515-01
4)	Only as a package E16-E17		1	539-226-01	539-226-01		1	539-132-01	539-132-01
5)	Only as a package E3-E5		1	508-128-03	508-128-03		1	508-128-03	508-128-03

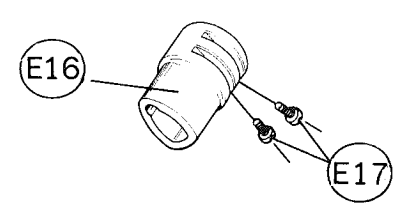
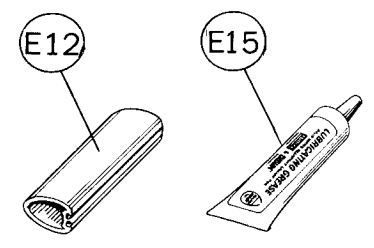
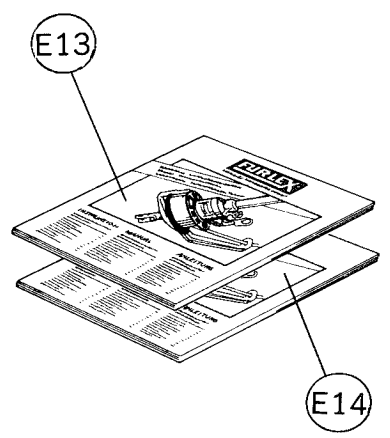
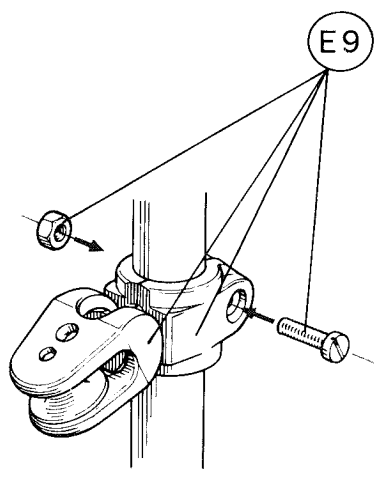
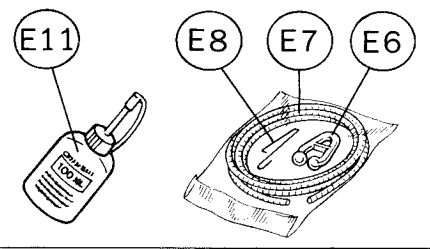
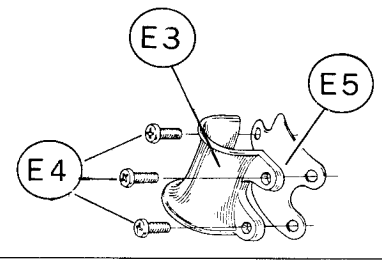
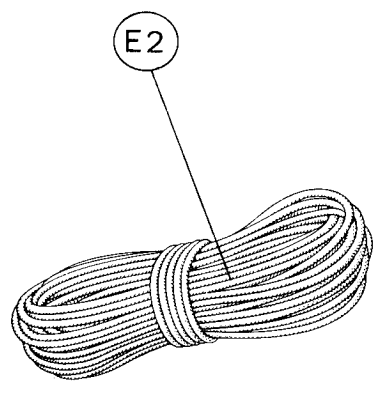
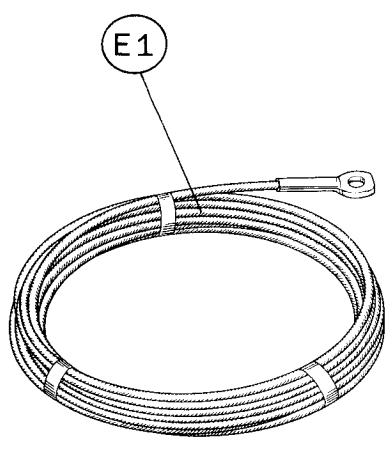
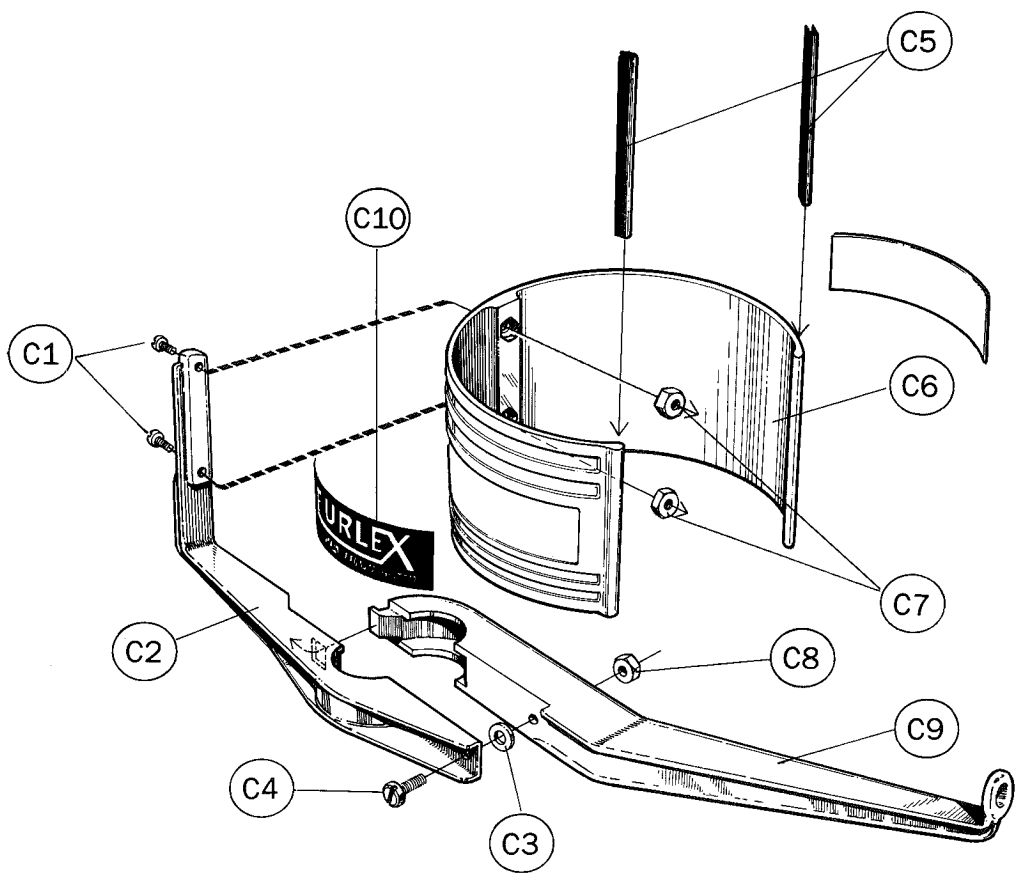

DESCRIPTION D

LUFF EXTRUSION 1000 MM

Item	Description	Type C				Type D			
		Dimension	Qty	Forestay wire size		Dimension	Qty	Forestay wire size	
				ø8mm	ø10 mm			ø12 mm	ø14 mm
		Assembly number →		539-210-01	539-210-01	Assembly number →		539-138-01	539-138-01
D 5	Distance tube	ø22 × ø11 × 750	1	535-627	535-627	—	—	—	—
D 6	Luff extrusion	40/27, L = 1000	1	539-210	539-210	50/34, L = 1000	1	539-138	539-138
D 7	Joint sleeve	26/23, L = 250	1	539-212	539-212	34/29, L = 1290	1	539-135	539-135

D 1	Sail feeder	Part no marked	1	505-510 1) 2)	505-510 1) 2)	Part no marked	1	505-512 1) 2)	505-512 1) 2)
D 2	Sail feeder connector	Part no marked	1	505-511 2)	505-511 2)	Part no marked	1	505-513 2)	505-513 2)
D 3	Screw	MCS 4 × 6	2	155-029 2)	155-029 2)	MCS 4 × 6	2	155-029 2)	155-029 2)
D 4	Insert thread	M 4 × 6	2	170-101 1) 2)	170-101 1) 2)	M 4 × 6	2	170-101 1) 2)	170-101 1) 2)
D 8	Connection spring	ø4 × 64	1	308-019	308-019	ø6 × 66	1	308-024	308-024
D 9	Connection spring	ø4 × 139	1	308-020	308-020	ø6 × 141	1	308-025	308-025
1)	Only as a package D1, D4		1	505-510-02	505-510-02		1	505-512-02	505-512-02
2)	D1-D4 also as a package		1	505-510-01	505-510-01		1	505-512-01	505-512-01

LUFF EXTRUSION 2000 MM

		Assembly number →		539-209-01	539-209-01	Assembly number →		539-137-01	539-137-01
D13	Joint sleeve	26/23, L = 250	1	539-212	539-212	34/29, L = 300	1	539-134	539-134
D14	Distance tube	ø22 × ø11 × 1750	1	535-628	535-628	ø28 × ø15 × 1700	1	535-631	535-631
D15	Luff extrusion	40/27, L = 2000	1	539-209	539-209	50/34, L = 2000	1	539-137	539-137

D16	Connection spring	ø4 × 64	1	308-019	308-019	ø6 × 66	1	308-024	308-024
-----	-------------------	---------	---	---------	---------	---------	---	---------	---------

LUFF EXTRUSION 2400 MM

		Assembly number →		539-208-01	539-208-01	Assembly Number →		539-136-01	539-136-01
D17	Joint sleeve	26/23, L = 250	1	539-212 3)	539-212 3)	34/29, = 300	1	539-134 3)	539-134 3)
D18	Luff extrusion	40/27, L = 2400	1	539-208 3)	539-208 3)	50/34, L = 2400	1	539-136 3)	539-136 3)
D19	Distance tube	ø22 × ø11 × 2150	1	535-629 3)	535-629 3)	ø28 × ø15 × 2100	1	535-632 3)	535-632 3)

D20	Connection spring	ø4 × 64	1	308-019 3)	308-019 3)	ø6 × 66	1	308-024 3)	308-024 3)
-----	-------------------	---------	---	------------	------------	---------	---	------------	------------

3)	D17-D20 also as a package		1	539-208-05	539-208-05		1	539-136-05	539-136-05
----	---------------------------	--	---	------------	------------	--	---	------------	------------

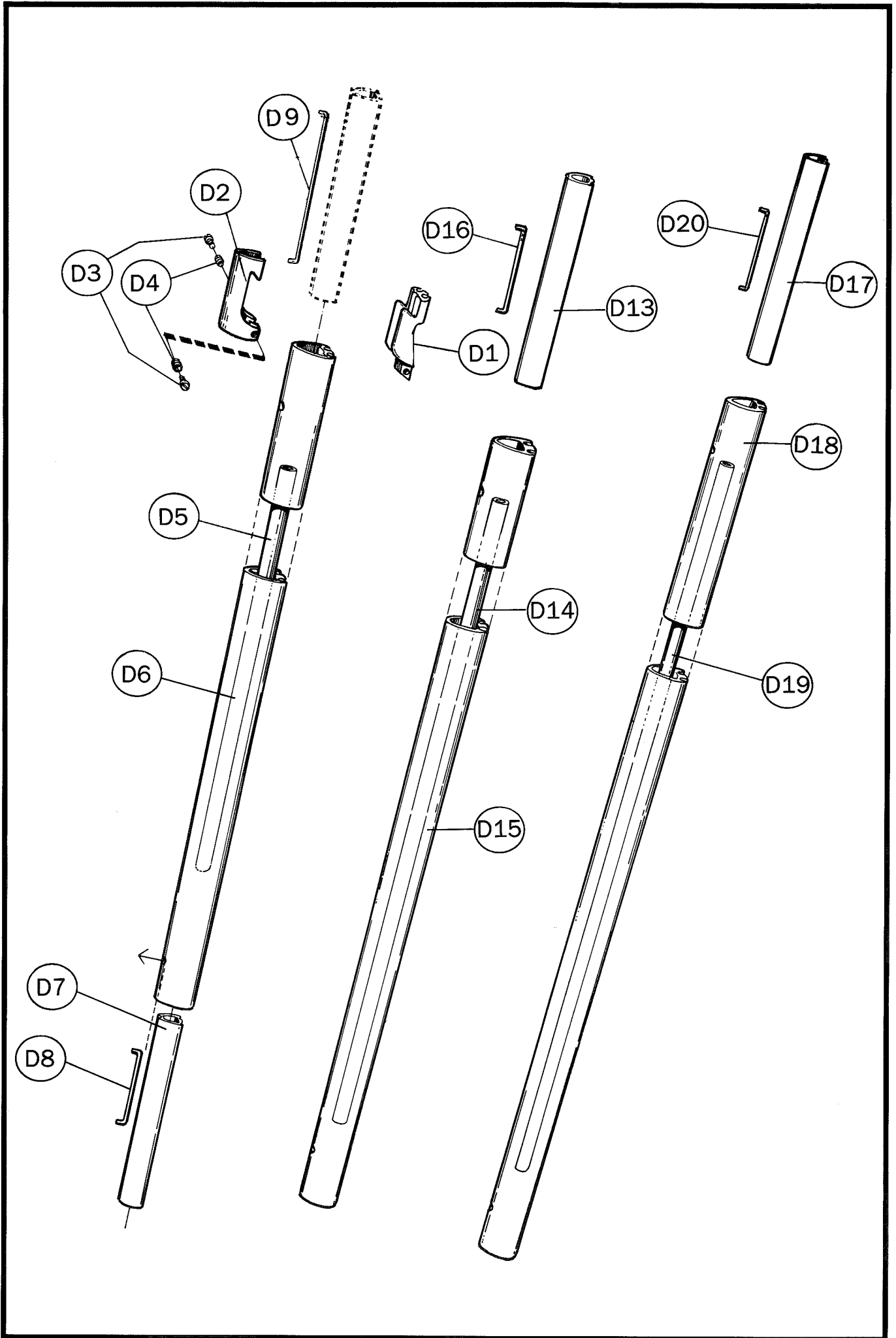

Bäste Furlex-ägare

Furlex säljs genom ett nät av auktoriserade återförsäljare som täcker alla marina marknader runt om i världen.

Auktorisationen omfattar praktisk och teoretisk utbildning i hur Furlex-systemet är uppbyggt. Denna kunskap innebär professionell service till Dig som Furlex-ägare.

Vi önskar dig mycket skön segling och hoppas att denna reservdels- och återförsäljarlista kan vara till nytta om du någon gång behöver kontakta en återförsäljare för professionella råd eller assistans.

Dear Furlex-owner

Furlex is supplied via an extensive network of authorized dealers who cover the major sailing areas of the world.

The authorization ensures that each dealer is fully versed in the design, assembly and operation of Furlex - and is a guarantee of professional service. We wish you much enjoyable and carefree sailing and hope that this spare parts- and dealerlist will be of help if you ever require professional advice or assistance.

Lieber Furlex-Eigner

Furlex wird über ein Netz autorisierter Fachhändler weltweit in allen Segelregionen verkauft.

Die Autorisierung dieser Fachhändler erfolgt durch eine theoretische und praktische Schulung im Aufbau des Furlex-Systems.

Dieses Können gewährleistet Ihnen als Furlex-Besitzer professionellen Service.

Wir wünschen Ihnen ein angenehmes Segeln und hoffen, daß Ihnen dieses Ersatzteil- und Fachhändlerverzeichnis hilft bei eventuellem Bedarf eines Rates oder professioneller Hilfe.



OBS!

Plocka ej isär fallsvirveln eller nedre lagringsdelen. Det kan vara svårt att återmontera dessa delar på ett korrekt sätt. Bland annat ligger lagerbanornas kullor löst monterade. Vid behov av service, kontakta din Furlex-återförsäljare.



NOTE!

Do not dismantle the halyard swivel or lower bearing assembly. You will find it difficult to re-assemble them correctly (the ball-bearings are loose and difficult to refit!). Contact your Furlex dealer if service is required.



ACHTUNG!

Nehmen Sie den Fallschlitten oder die untere Lagerung nicht auseinander. Es ist schwer diese wieder korrekt zu montieren. Unter anderem liegen die Kugeln lose montiert. Wenden Sie sich bei Bedarf an Ihren Furlex-Händler.

Fast access to our know-how, worldwide



The Seldén Group is one of the world's leading manufacturers of spar and rigging systems. Our comprehensive range caters for dinghies, performance dayboats and yachts up to 30 tonnes. The group consists of Seldén Mast AB and YRAB, both in Sweden, Seldén Mast Ltd in the UK and Seldén Mast Inc in the USA. Our well known product names are Seldén, Furlex, Furlin', Furlex Main, Proctor and Hasselfors.

At Seldén we are sailors. Our extensive sailing experience, combined with practical engineering knowledge, is at the heart of our business. It guarantees care, attention to detail and a total commitment to quality.

With development and production facilities on Sweden's west coast, England's south coast and the east coast of the USA, we have unique opportunities to test and develop our products under tough, practical, sea-going conditions. All manufacturing is carried out in accordance with strict quality control routines.

Our quality philosophy does not stop at the production line, but is extended to our authorized distribution and service network through a complete programme of training courses, instruction manuals and films. Everything, in fact, to ensure customer satisfaction.

Based on our global success with Furlex we have built a network of over 700 authorized dealers covering the world's marine markets. So wherever you sail, you can be sure of fast access to our service, spare parts and know-how.



SELDÉN